

## Outline Dimension

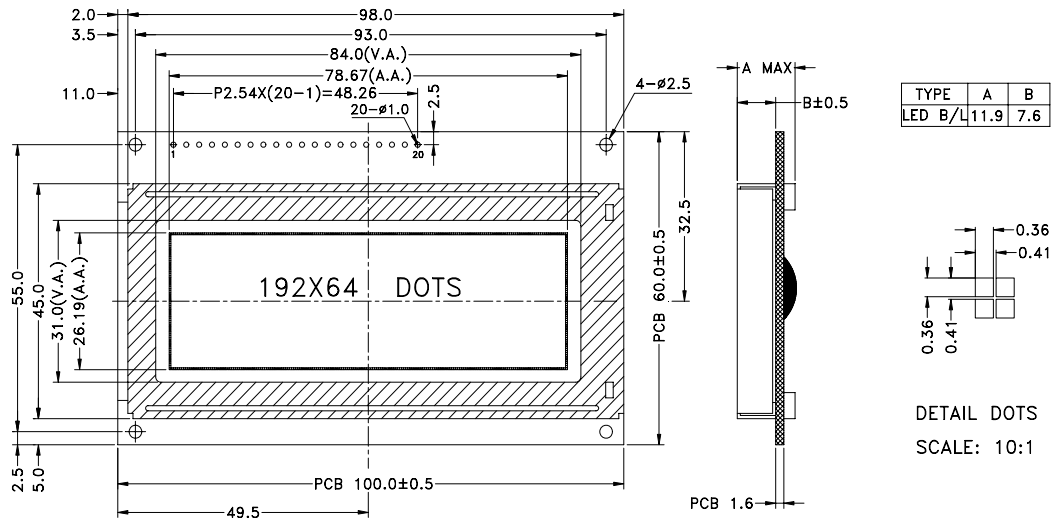

## Graphic Type

### Feature :

- 192x64 dot-matrix
- STN/Transflective/Positive/Y-G
- Yellow green /Side light (LED)
- Operating Temp.: -20°C ~ +70°C
- 1/64 duty cycle, 1/9 Bias
- Built-in Controller (SBN0064G or equivalent)
- Viewing angle: 6 o'clock

### Electrical Characteristic : (V<sub>SS</sub>=0V, T<sub>a</sub> = 25°C)

Parameter	Symbol	Condition	M <sub>IN</sub>	T <sub>YP</sub>	M <sub>AX</sub>	Unit
Supply voltage for logic	V <sub>DD</sub>	--	4.8	5.0	5.2	V
Supply current for logic	I <sub>DD</sub>	--	--	4	--	mA
Operating voltage for LCD	V <sub>LCD</sub>	-20°C	--	--	--	V
		+25°C	--	12.5	--	V
		+70°C	--	--	--	V
Supply voltage for Backlight	V <sub>BL</sub>	--	--	5.0	--	V
Supply current for Backlight	I <sub>BL</sub>	--	--	45	--	mA

### Absolute Maximum Rating :

Item	Symbol	Standard value			Unit
		M <sub>IN</sub>	T <sub>YP</sub>	M <sub>AX</sub>	
Power supply for logic	V <sub>DD</sub> -V <sub>SS</sub>	-0.3	--	7.0	V
Input voltage	V <sub>I</sub>	-0.3	--	V <sub>DD</sub> +0.3	V

### Adjusting Display Contrast :

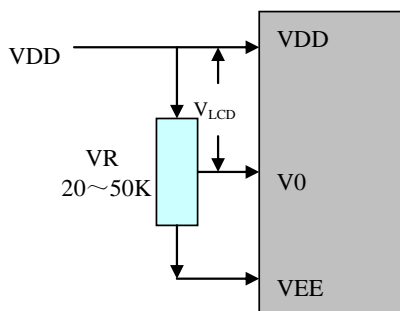

Note: Adjust V0 to VDD as an initial setting. When the module is operational, readjust V0 for optimal display appearance.

### Interface Pin Connections :

Pin No.	Symbol	Level	Description
1-8	DB7-DB0	H/L	Bi-direction, tri-state 8-bit parallel data bus for interface with a host microcontroller. This data bus is for data transfer between the host microcontroller and the SBN0064G.
9	E	H/L	Enable signal (E) from the host microcontroller.
10	R/W	H/L	Read/Write(R/W) control signal from the host microcontroller. This pin should be connected to the R/W output of the host microcontroller. A HIGH level on this pin indicates that the microcontroller intends to do a WRITE operation.
11	C/D	H/L	Command/Data selection from the host microcontroller. When C/D=0, the data on the 8-bit data bus(DB0~DB7) are either code data to be written to an internal register, or status from the internal status register. When C/D=1, the data on the 8-bit data bus(DB0~DB7) are data to be written to or read from the display data memory.
12	V0	--	LCD driver supplies adjusting voltages.
13	VDD	+5.0V	Supply voltage for logic operating.
14	VSS	0V	Ground output for pad option.
15	CSA	H/L	When CSA&CSB= "0", the left area is active; When CSA = "1"&CSB = "0", the right area is active; When CSA = "0"&CSB = "1", the middle area is active;
16	CSB	H/L	
17	VOUT	--	
18	/RST	H/L	When /RES is set to "L," the settings are initialized.
19	LED+	+5.0V	Power supply for backlight.
20	LED-	0V	Ground for backlight.