

RoHS Compliant

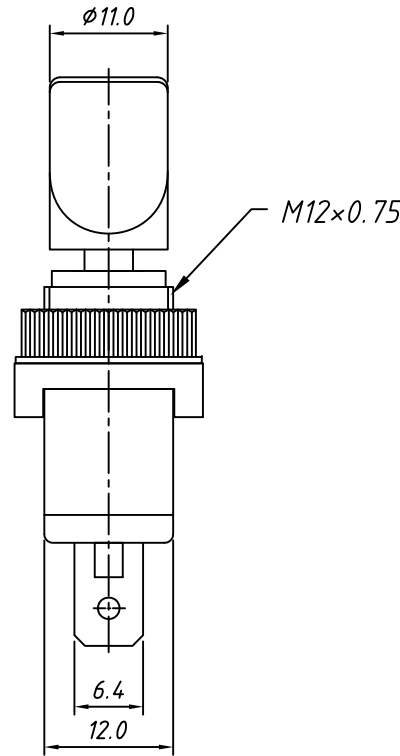

Electrical
 Rated voltage/current: 20A 12V DC
 Contact Resistance: 50 m Ω
 Insulation resistance: 100MΩ/DC500V
 Withstand voltage: AC1500V / 1 min
 Temp. Range: -25 °C ~ +85 °C
 Life: 10000 cycles

Order Information

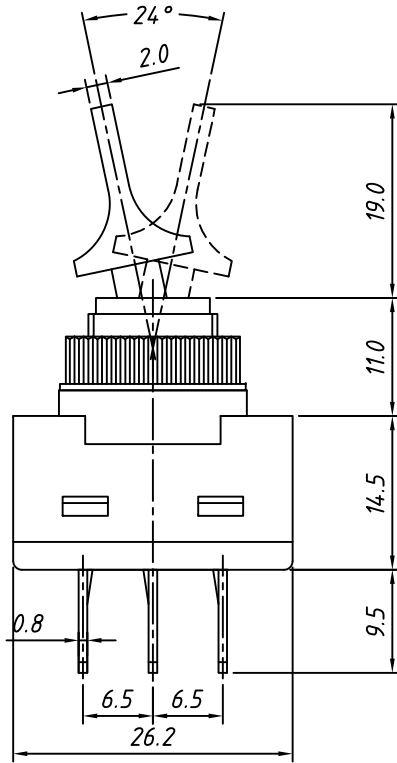
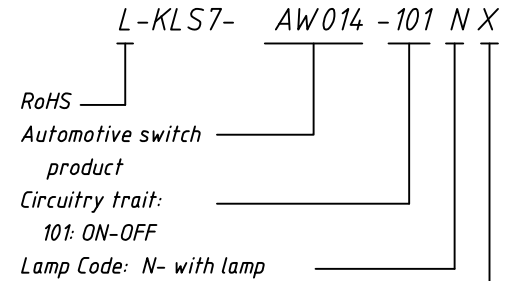

Shell color Code:
 R- Transparency Red
 G- Transparency Green
 L- Transparency Blue
 Y- Transparency Yellow

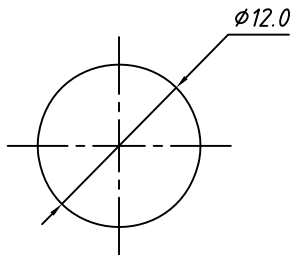

Panel Mounting

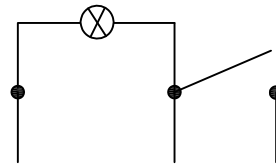

Circuitry

GENERAL TOLERANCE		ANGLE TOLERANCE		Description:	Automotive Switch
X. ±0.60		X. ±5°		SPST 3P, with Lamp, ON-OFF	
.X ±0.38		.X ±3°		KLS P/N:	KLS7-AW014-101Nx
.XX ±0.25		.XX ±2°			
Draw by	2015-09-01	PROJECTION		NingBo KLS ELECTRONIC CO.,L TD.	
Check by	2015-09-15	UNITS	mm		
SCALE		SHEET SIZE	A4		

RoHS Compliant

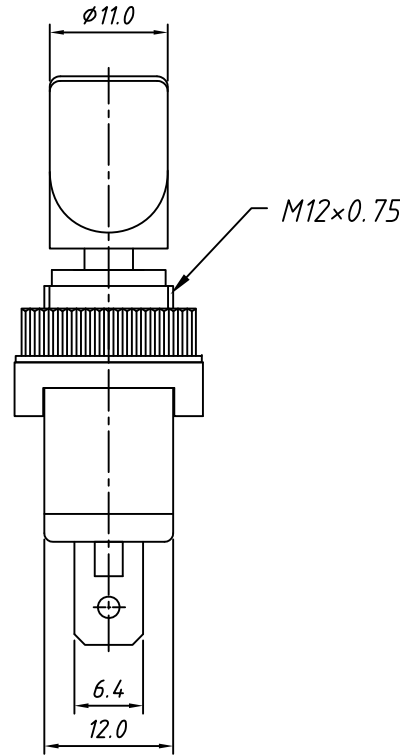
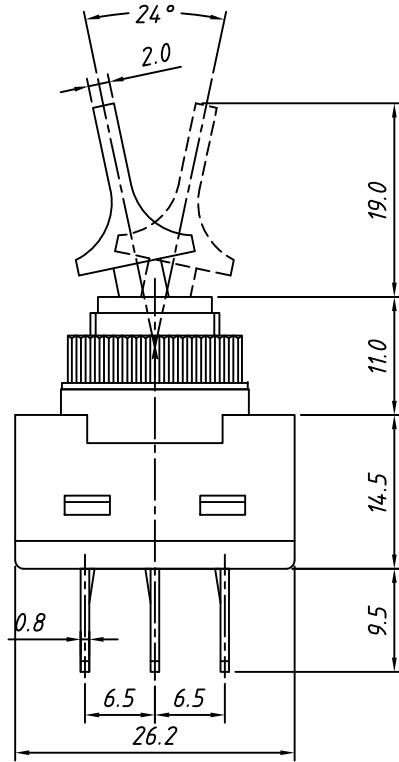

Electrical
 Rated voltage/current: 20A 12V DC
 10A 125V AC
 Contact Resistance: 50 mΩ
 Insulation resistance: 100MΩ/DC500V
 Withstand voltage: AC1500V / 1 min
 Temp. Range: -25 °C ~ +85 °C
 Life: 10000 cycles

Order Information

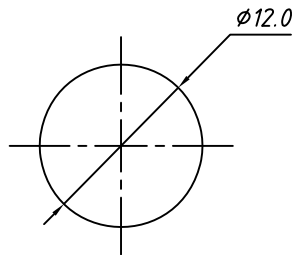
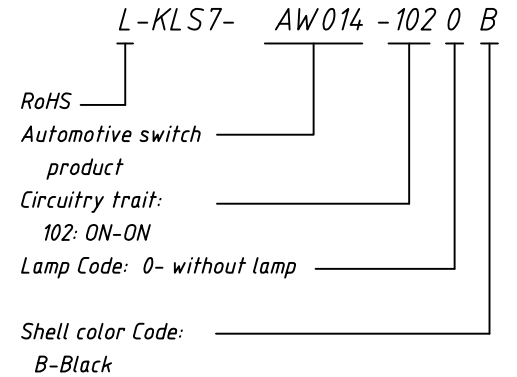

Panel Mounting

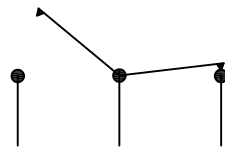

ON-ON

Circuitry

GENERAL TOLERANCE		ANGLE TOLERANCE		Description:	Automotive Switch
X. ±0.60		X. ±5°		SPST 3P, without Lamp, ON-ON	
.X ±0.38		.X ±3°		KLS P/N:	KLS7-AW014-1020B
.XX ±0.25		.XX ±2°			
Draw by	2015-09-01	PROJECTION		NingBo KLS ELECTRONIC CO.,L TD.	
Check by	2015-09-15	UNITS	mm		
SCALE		SHEET SIZE	A4		

RoHS Compliant

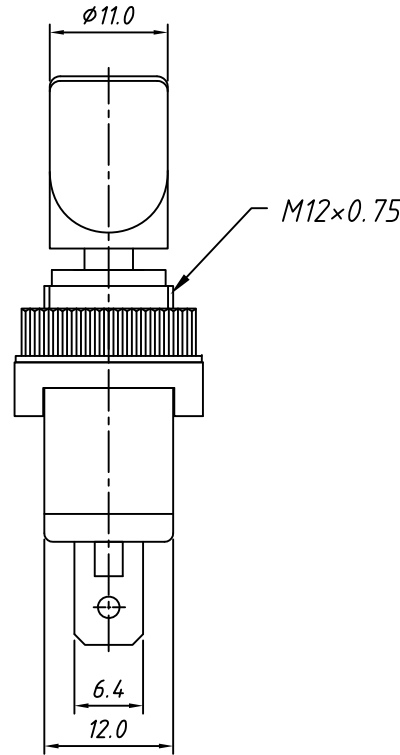
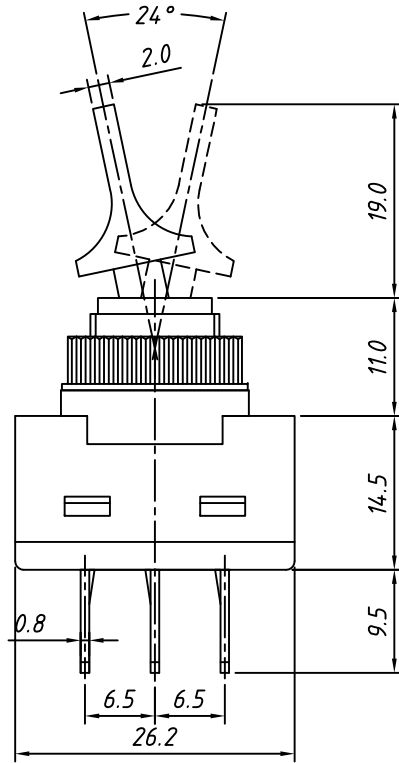

Electrical

Rated voltage/current: 20A 12V DC
 10A 125V AC
 Contact Resistance: 50 mΩ
 Insulation resistance: 100MΩ/DC500V
 Withstand voltage: AC1500V / 1 min
 Temp. Range: -25 °C ~ +85 °C
 Life: 10000 cycles

Order Information

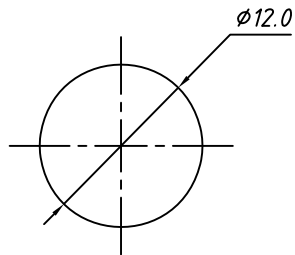
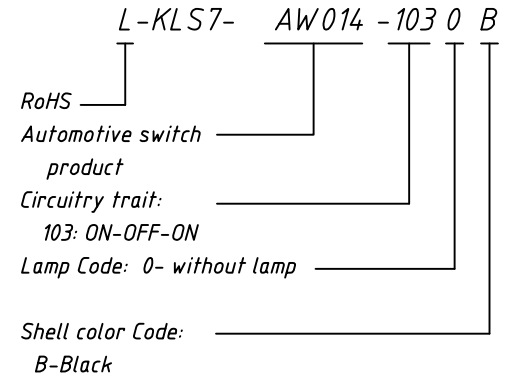

Panel Mounting

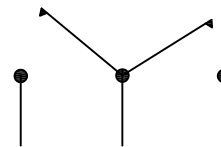

ON-OFF-ON

Circuitry

GENERAL TOLERANCE		ANGLE TOLERANCE		Description:	Automotive Switch
X. ±0.60		X. ±5°		SPST 3P, without Lamp, ON-OFF-ON	
.X ±0.38		.X ±3°		KLS P/N:	KLS7-AW014-1030B
.XX ±0.25		.XX ±2°			
Draw by	2015-09-01	PROJECTION		NingBo KLS ELECTRONIC CO.,L TD.	
Check by	2015-09-15	UNITS	mm		
SCALE		SHEET SIZE	A4		

RoHS Compliant

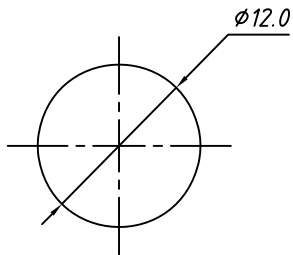
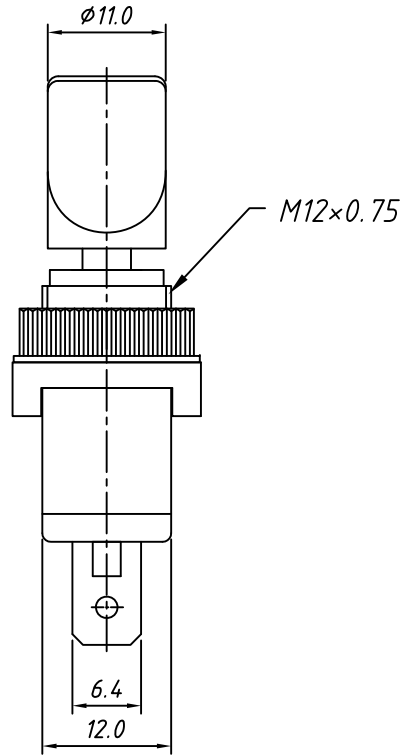
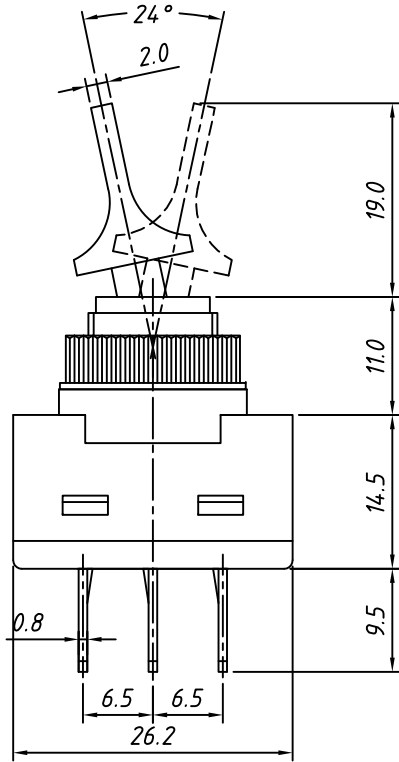

Panel Mounting

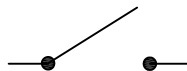

ON-OFF

Circuitry

Electrical

Rated voltage/current: 20A 12V DC
 10A 125V AC
 Contact Resistance: 50 mΩ
 Insulation resistance: 100MΩ/DC500V
 Withstand voltage: AC1500V / 1 min
 Temp. Range: -25 °C ~ +85 °C
 Life: 10000 cycles

Order Information

L-KLS7- AW014 -101 0 B

RoHS
 Automotive switch
 product
 Circuitry trait:
 101: ON-OFF
 Lamp Code: 0- without lamp
 Shell color Code:
 B-Black

GENERAL TOLERANCE		ANGLE TOLERANCE		Description:	Automotive Switch
X. ±0.60		X. ±5°		SPST 2P, without Lamp, ON-OFF	
.X ±0.38		.X ±3°		KLS P/N:	KLS7-AW014-1010B
.XX ±0.25		.XX ±2°			
Draw by	2015-09-01	PROJECTION			NingBo KLS ELECTRONIC CO.,L TD.
Check by	2015-09-15	UNITS	mm		
SCALE		SHEET SIZE	A4		